

Spare parts list

Handheld pneumatic pick hammers

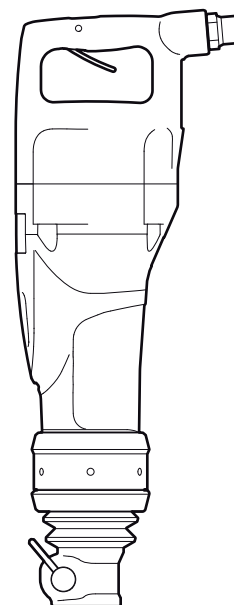

Contents

General information.....	5
Spare parts list.....	6
TEX 09PE	6
Working tools.....	9
ISO standard hexagon 22 x 82.5 mm (7/8 x 3¼ in.)	9
Round 25 x 75 mm (1 x 3 in.)	10
Accessories.....	11
Breaker and hammer AIR-OIL	11
Optional equipment	12

General information

This spare parts list applies to the following:

Part number	Description
8461 0211 35	Handheld pneumatic breaker TEX 09PE H22 x 82.5 mm (H7/8 x 3¼ in.)
8461 0211 36	Handheld pneumatic breaker TEX 09PE R25 x 75 mm (R1 x 3 in.)

Use only authorized parts. Any damage or malfunction caused by the use of unauthorized parts is not covered by Warranty or Product Liability. Any unauthorized use or copying of the contents or any part thereof is prohibited. This applies in particular to trademarks, model denominations, part numbers, and drawings.

Instructions for use

This spare parts list contains no safety regulations and is merely intended to assist in the ordering of spare parts.

For information about operating, servicing, or repairing, the relevant Safety and operating instructions must be consulted at all costs.

Please observe the safety instructions listed in the relevant Safety and operating instructions!

Spare parts list

TEX 09PE

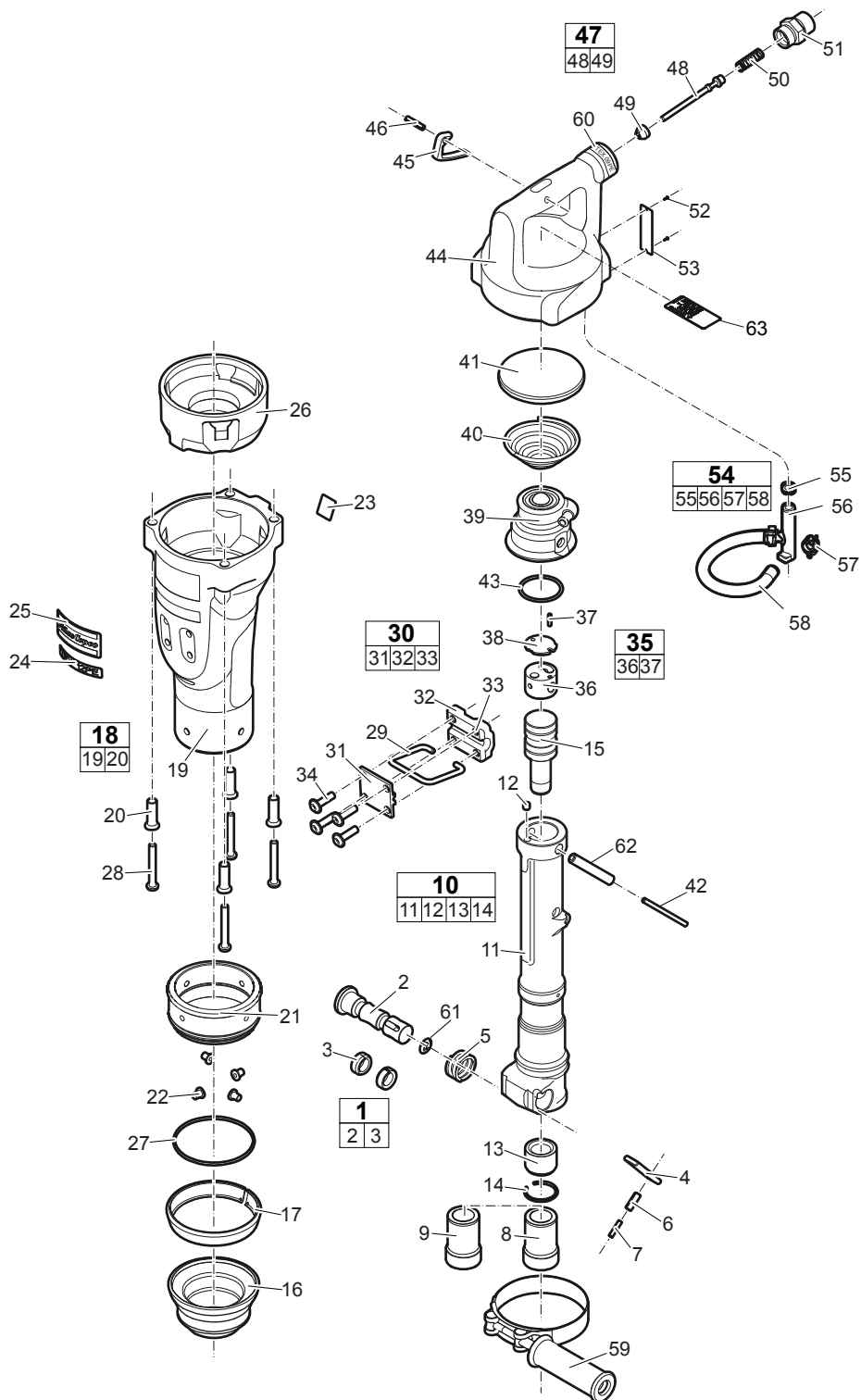

No.	Description	Remark	Quantity	Part number
1(2-3)	Tool retainer, complete		1	3310 1413 80
2	Tool retainer		1	-
3	Bush		2	3310 1414 00
4	Lever		1	3310 1415 00
5	Spring		1	3310 1486 00
6	Spring pin		1	0108 1103 16
7	Spring pin		1	0108 1103 17
8	Chuck, hexagon	For TEX 09PE hexagon 22 x 82.5 mm	1	3310 1316 00
9	Chuck, round	For TEX 09PE round 25 x 75 mm	1	3310 1317 00
10(11-14)	Cylinder, complete		1	3310 1400 80
11	Cylinder		1	-
12	Plug		1	3310 1473 00
13	Intermediate part		1	3310 0870 00
14	Lock ring		1	3310 0871 00
15	Piston		1	3310 1398 00
16	Bellow		1	3310 1412 00
17	Clamping ring		1	3310 1407 00
18(19-20)	Silencer, complete		1	3310 1404 80
19	Silencer		1	-
20	Bush		4	3310 1555 00
21	Ring		1	3310 1406 00
22	Hexagon socket screw		4	0215 0006 35
23	Sound label		1	-
24	Label		1	3310 1553 01
25	Label		1	0690 1101 02
26	Buffer ring		1	3310 1592 00
27	O-ring		1	0663 6143 00
28	Hexagon socket screw	MC6S 8 x 60 8.8	4	0211 1102 24
29	Link arm		1	3310 1409 00
30(31-33)	Bearing, complete		1	3310 1410 80
31	Upper plate		1	-
32	Lower plate		1	-
33	Thread insert		4	-
34	Hexagon socket screw		4	0215 0006 36
35(36-37)	Cover, complet		1	3310 1386 80
36	Cover		1	-
37	Pin		1	0102 0242 00
38	Main valve		1	3310 1394 00
39	Valve house		1	3310 1447 80
40	Conical spring		1	3310 1445 00
41	Spring seat		1	3310 1545 00
42	Pin		1	3310 1599 00
43	O-ring		1	0663 2111 69
44	Back head		1	3310 1425 00
45	Trigger		1	3310 1421 00
46	Spiral pin		1	0108 3328 00
47(48-49)	Valve stem, complete		1	3310 1281 80
48	Valve stem		1	-
49	Inlet valve		1	3310 1135 00
50	Spring		1	3310 1130 00
51	Nipple	¾ in. -14 NTP	1	3310 1131 01
52	Screw		2	0244 4144 00
53	Data plate		1	-

No.	Description	Remark	Quantity	Part number
54(55-58)	Hose, complete		1	3310 1554 90
55	Seal		1	3310 1556 00
56	Nipple		1	-
57	Spring band clamp		2	0347 0102 05
58	Hose		1	-
59	Handle		1	3310 1557 80
60	Label		1	3310 1553 03
61	Label		1	8915 0021 43
62	Bushing		1	3310 1575 00
63	Label	Safety	1	3310 1602 00

Working tools

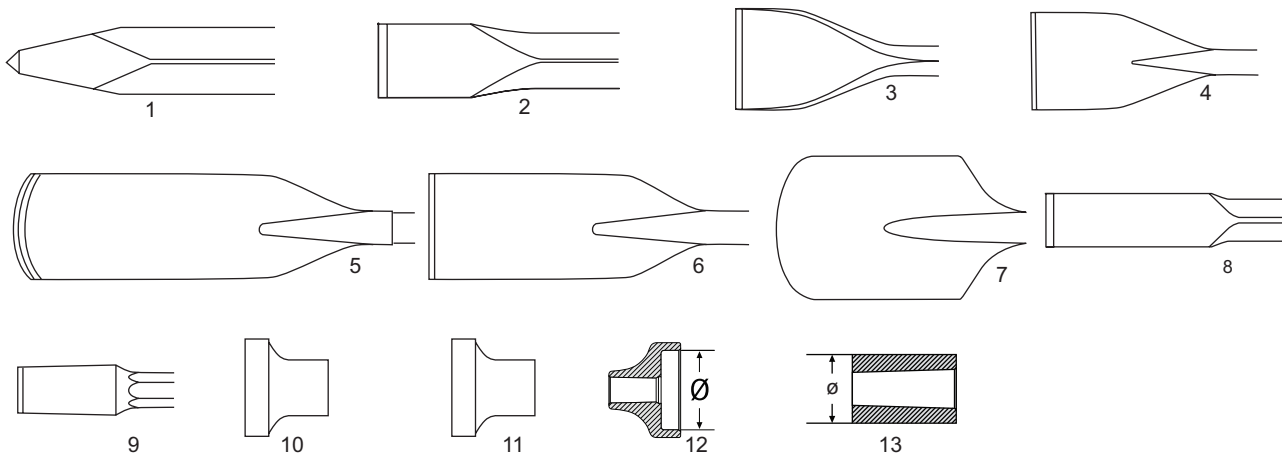

ISO standard hexagon 22 x 82.5 mm (7/8 x 3 1/4 in.)

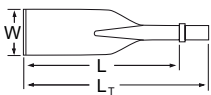

Point to flat



No.	Description	W (mm)	L (mm)	L _T (mm)	Wt (kg)	Part number
1	Moil point	-	380	475	1.6	3083 3242 00
		-	1000	1095	3.6	3083 3243 00
2	Narrow chisel	-	380	475	1.6	3083 3244 00
		-	1000	1095	3.6	3083 3245 00
3	Wide chisel	75	380	475	2.2	3083 3246 00
4	Asphalt cutter	125	380	475	3.0	3083 3069 00
5	Digging chisel	75	450	545	3.3	3083 3247 00
6	Digging spade	120	400	495	3.8	3083 3248 00
7	Clay spade	125	430	525	3.7	3083 3249 00
8	Frost wedge	35	380	475	2.3	3083 3250 00
9	Shaft for tamping pad	-	310	405	1.7	3083 3251 00
10	Tamping pad, round	Ø175	-	-	7.6	3083 3252 10
11	Tamping pad, square	175	-	-	6.1	3083 3239 00
12	Driver pad, round	Ø65	-	-	1.9	3317 8060 12
		Ø100	-	-	2.6	9245 2817 90
14	Posthole tool	40	-	-	2.7	9245 2822 30

Round 25 x 75 mm (1 x 3 in.)

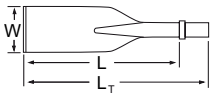

No.	Description	W (mm)	L (mm)	L _T (mm)	Part number
1	Moil point	-	330	415	3083 3265 00
		-	450	535	3083 3265 10
2	Narrow chisel	-	330	415	3083 3266 00
		-	450	535	3083 3266 10

Accessories

Breaker and hammer AIR-OIL

Description	Remark	Quantity	Part number
Breaker and hammer AIR-OIL	0.25 l 0.06 US gallon	1	8099 0202 40
Breaker and hammer AIR-OIL	1 l 0.26 US gallon	1	8099 0202 36
Breaker and hammer AIR-OIL (pack)	1 l 0.26 US gallon	20	8099 0202 81
Breaker and hammer AIR-OIL	5 l 1.32 US gallon	1	8099 0202 02
Breaker and hammer AIR-OIL (pack)	5 l 1.32 US gallon	4	8099 0202 85

Optional equipment

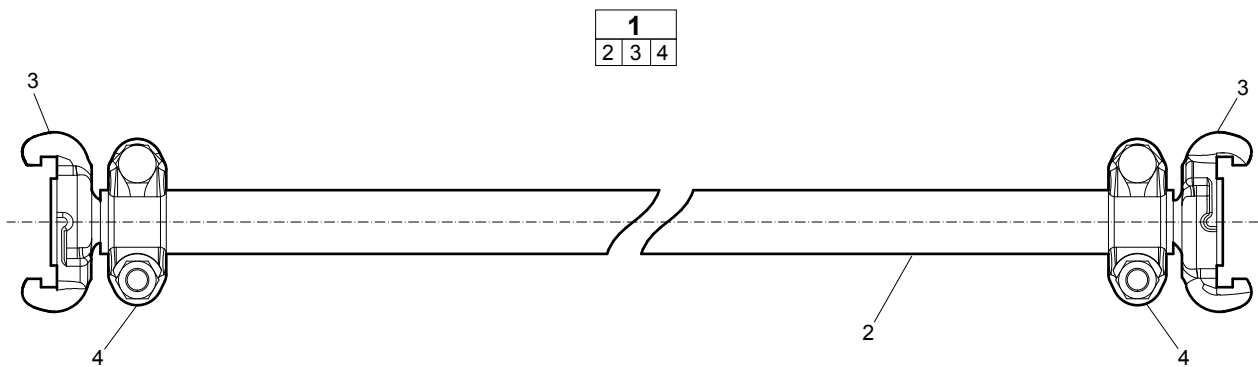

No.	Description	Remark	Quantity	Part number
1(2-4)	Handhose with couplings and hose clamps		1	9030 2090 00
2	Rubber hose	L = 3 m L = 118.11 in.	1	9030 2090 03
3	Claw coupling	ø12.5 mm ø0.50 in.	2	9000 0310 00
4	Hose clamp	ø12.5 mm ø0.50 in.	2	9000 0194 00

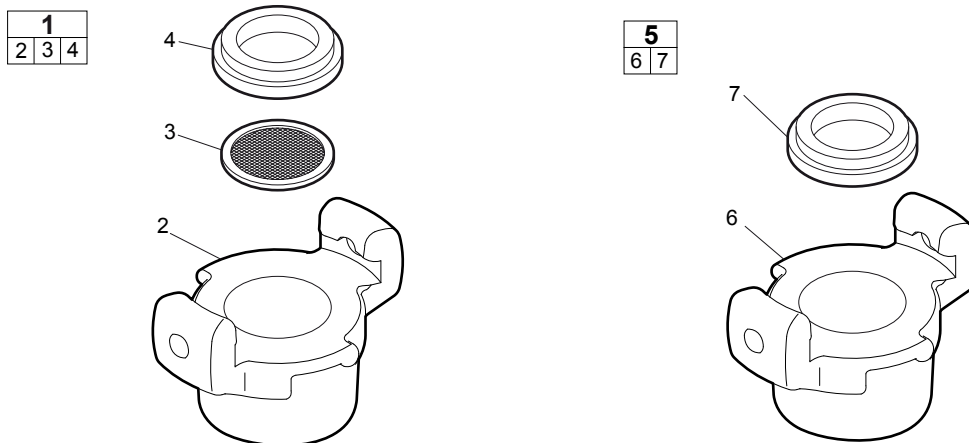

No.	Description	Remark	Quantity	Part number
1(2-4)	Claw coupling with strainer, complete		1	9000 0306 01
2	Claw coupling	Standard G $\frac{3}{4}$ in.	1	-
3	Strainer		1	9000 0000 10
4	Seal		1	9000 0000 00
5(6-7)	Claw coupling, complete		1	9000 0306 00
6	Claw coupling	Standard G $\frac{3}{4}$ in.	1	-
7	Seal		1	9000 0000 00



Any unauthorized use or copying of the contents or any part thereof is prohibited.
This applies in particular to trademarks, model denominations, part numbers, and drawings.

© 2013 Atlas Copco Construction Tools AB | No. 9800 0815 01d | 2013-01-12

www.atlascopco.com